



Keli Electric Manufacturing(Ningbo)Co.,Ltd.

### NHS-A/-ASS Loadcell

### NHS-A/-ASS



Rated Load ( t )	H
47	230
68	240

NHS 100t

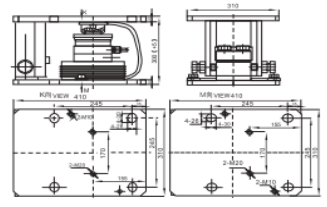

NHS 150t

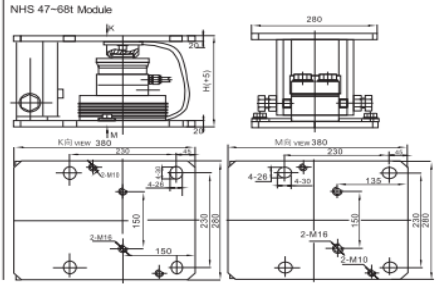
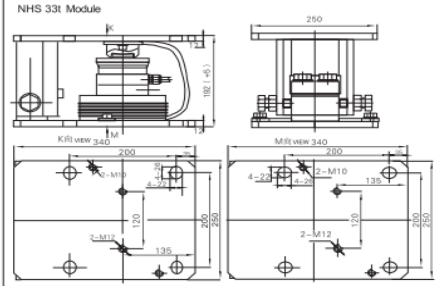
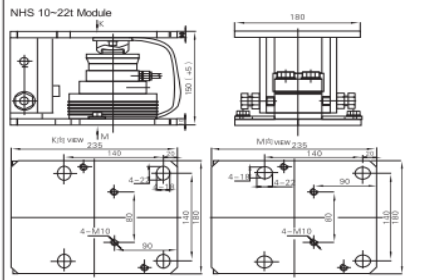
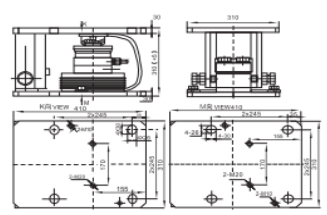

Keli Electric Manufacturing(Ningbo)Co.,Ltd.

### NHS-A/-ASS Loadcell

### NHS-A/-ASS

10-150t

Rated Load(t)	A	B	C	H	J	K
10-22	75	30	75	50	7	6.5
33	85	40	85	65	7	10
47	130	60	130	75	7	14
68	130	60	130	85	7	14
100	150	70	150	90	7	16
150	150	70	150	100	7	16

1-4.7t

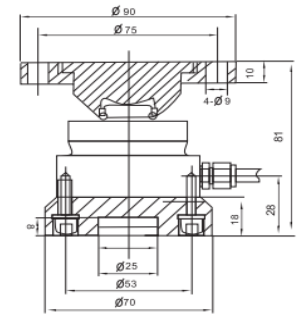

10-100t

Rated Load(t)	A	B	C	D	E	H	K	J	N
10-22	45	75	55	80	100	35	20	11.5	10
33	65	95	65	95	120	45	25	13	12
47	80	130	82	130	170	140	30	17.5	20
68	80	130	82	130	170	150	30	17.5	20
100	100	150	110	150	200	177	40	25	22
150	100	150	110	150	200	187	40	25	22

Thickness of the limited pin is 10mm, recommended depth for the installation base plate is 6mm

Axle wheel scale, hopper scale, Silo scale

### TECHNICAL PARAMETER | OAP version 4Wires:Exc+(Blue);Exc-(Black);Sig+(White);Sig-(Red)

Rated capacities(Emax)	1,2,2.3,3,4,7,10,15,22,33,47,68,100,150t	Temperature range, compensated	-10°C~+40°C
Sensitivity	2.85±0.015mV/V	Temperature range, operating	-30~+70°C
Total error	±0.03, ±0.05, ±0.1%F.S	Maximum safe overload	150%F.S
Creep error (30min)	±0.03%F.S	Ultimate overload	200%F.S
Zero balance	±1%F.S	Excitation, recommended	10~12V DC
TC ZERO	±0.03%F.S/10°C	Excitation, maximum	15V DC
TC SPAN	±0.03%F.S/10°C	Protection class	IP68
Input resistance	1450 ± 10 Ω	Construction	Alloy Steel Stainless Steel
Output resistance	1402 ± 5 Ω (L ≥ 15m)	Cable	Length=L.8m(1-4.7t), 12m(10-33t), 16m(47-150t)
Insulation resistance	≥5000M Ω		Diameter: φ6mm

